

# Spectroscopy

## Minneapolis Community and Technical College

v.7.20

**Objective:** To observe, measure and compare line spectra from various elements and to determine the energies of those electronic transitions within atoms that produce lines in a line spectrum.

**Prelab Questions:** Read through this lab handout and answer the following questions before coming to lab. There will be a quiz at the beginning of lab over this handout and its contents.

1. How does the spacing of stationary states change as  $n$  increases?
2. For the hydrogen atom, why isn't light produced by the  $n = 3 \rightarrow n = 1$  electron transition visible to the eye?
3. How does the energy of an  $n = 3 \rightarrow 2$  electronic transition compare to the energy of a  $2 \rightarrow 1$  transition?
4. What is the meaning of ROY G BIV?
5. What are the meanings of the terms "absorbed" and "transmitted."
6. How is an emission spectrum different from an absorption spectrum?
7. What is a spectroscope?
8. Where does light enter the spectroscope?
9. What is the wavelength of the spectral line displayed in the figure at right?
10. Calculate the energy corresponding to hydrogen's  $n = 1$  stationary state.

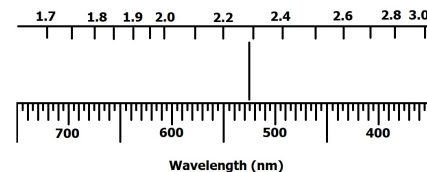

### The Bohr Atom, Stationary States and Electron Energies

Bohr's theory of the atom locates electrons within an atom in discrete "stationary states". The "n" quantum number identifies each stationary state with a positive integer between 1 and infinity ( $\infty$ ). Larger n values correspond to larger electron orbits about the nucleus.

Stationary states energies are described using a potential energy ladder diagram at right. Electrons are forbidden from having energies between stationary states.

The potential energy of an electron depends on which stationary state is occupied. The lowest energy stationary state is given by  $n=1$ . Electrons found in higher stationary states have progressively higher potential energies. Thus, electrons in the  $n=3$  stationary state have greater potential energy than those electrons in the  $n=2$  stationary state.

An "electron transition" refers to an electron moving from one stationary state to another. As an electron transitions between stationary states, its potential energy within the atom changes. For example, when an electron transitions from  $n = 5 \rightarrow n = 2$ , the electron loses potential energy that is released as light energy (Conservation of Energy).

Because electron energies are limited to only those in the ladder diagram, electron transitions can only produce light of specific energies. In the diagram below, hydrogen atom transitions all

High Electron Potential Energy

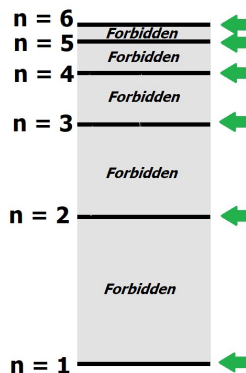

Low Electron Potential Energy

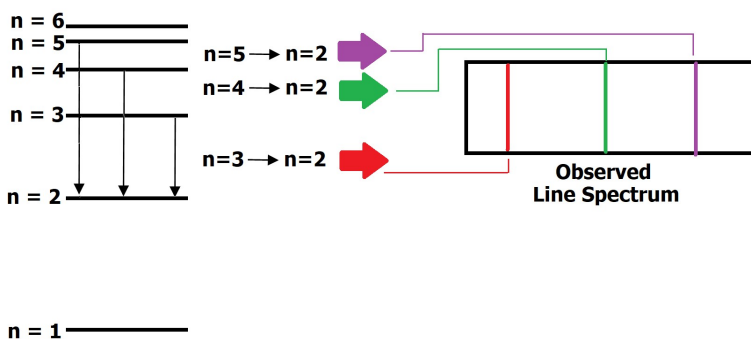

ending on the  $n=2$  level are shown.

The  $n = 5 \rightarrow n = 2$  transition produces violet light that appears in the spectrum as a single violet line. Other electron transitions,  $n = 4 \rightarrow n = 2$  and  $n = 3 \rightarrow n = 2$  also produce light that is observed as green and red lines in the spectrum.

Electronic transitions between other energy levels also occur but the light released isn't visible to the naked eye. Furthermore, upward electronic transitions are also allowed but require an outside source of energy to "promote" the electron.

### Emission Spectra: When light is produced.

When the white light produced by the sun or an incandescent light bulb is separated using a prism or spectrometer, the result is the visible spectrum where all colors are present. (figure at right).

The order of the colors, given by the fictitious name Roy G. Biv lists the colors in order of increasing energy (i.e. red light is lower energy light than orange).

When the light that emerges from the prism is projected on a screen (or your eye's retina), a continuous spectrum is observed:

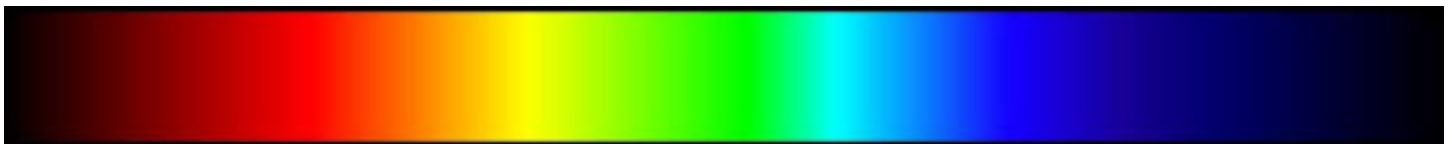
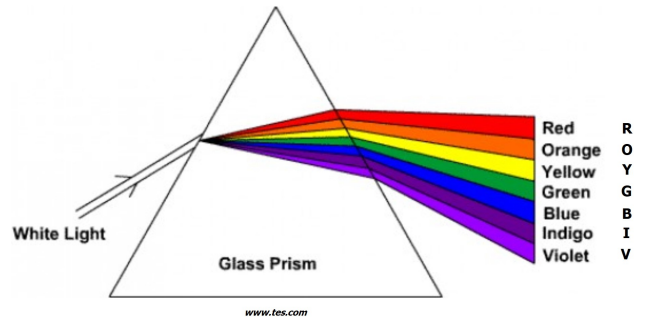

However, when the light produced by atoms is separated using a prism or spectrometer, the observed spectrum is found to consist of discrete bands or lines of light separated by darkness. No lines are observed in the dark regions since there were no electron stationary state transitions capable of producing light in these regions.

The line spectrum is unique to the element that produced it. Line spectra are essentially "fingerprints" for an element and can be used to unambiguously identify it. In fact, it was helium's line spectrum (below) appearing in sunlight that led to the element's discovery in 1868 by French astronomer Pierre-Jules-César Janssen.

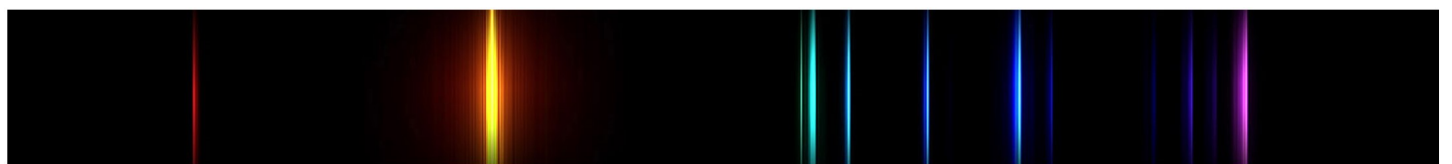

[https://commons.wikimedia.org/wiki/File:Visible\\_spectrum\\_of\\_helium.jpg](https://commons.wikimedia.org/wiki/File:Visible_spectrum_of_helium.jpg)

Below is the hydrogen spectrum you will be studying. Notice that as the smallest atom, hydrogen has the simplest line spectrum. You'll find that larger atoms (Helium above) have increasingly more complicated line spectra.

Hydrogen's first three lines, red, blue and violet, are usually easy to see. The deep violet lines at the far right are fainter and in a region of the spectrum that not all people have the ability to see. (BTW, if you can see the far violet lines while doing the experiment, you can claim that as one of your superpowers)



[https://commons.wikimedia.org/wiki/File:Visible\\_spectrum\\_of\\_hydrogen.jpg](https://commons.wikimedia.org/wiki/File:Visible_spectrum_of_hydrogen.jpg)

## Absorption Spectra: When light is absorbed.

In the figure at right, a white light source is aimed at the sample. Although the white light is a mixture of all visible wavelengths, not all are able to pass through the sample. Consequently, those wavelengths (colors) that don't pass through the sample we say are "absorbed."

In the example at right, green and yellow light fail to pass through the sample. We say that the green and yellow light was absorbed.

Alternatively, light that does pass through the sample, like the red and blue light, is transmitted.

Using a spectroscope or prism, we can observe what parts of the spectrum have been removed or absorbed. The observed spectrum is called an absorption spectrum. Light that is transmitted appears in the spectrum while light that is absorbed is replaced by darkness.

Typically, molecular species will absorb large segments of the available light spectrum as seen above.

On the other hand, atomic species absorb thin slices or lines that correspond to identical positions in the emission spectrum. In the lithium emission spectrum below, six emission lines are observed. When white light is projected through a gaseous lithium sample, most colors are transmitted. However, segments of the continuous spectrum that coincide with the emission spectrum are absorbed. These appear as dark lines in the absorption spectrum.

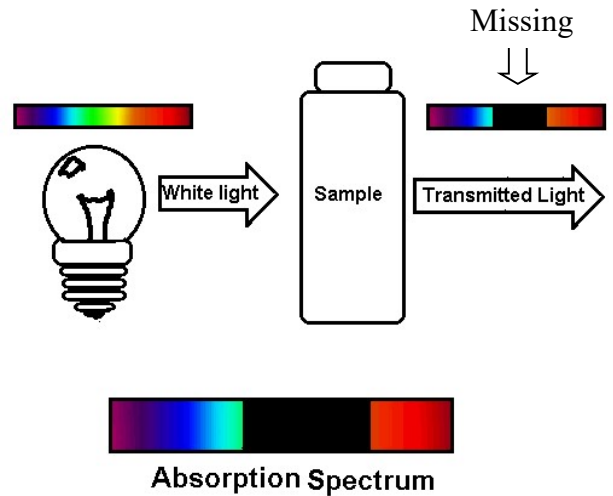

### Lithium Emission Spectrum



### Lithium Absorption Spectrum



<http://www.astronoo.com/images/elements/spectre-absorption-element.png>

## Prelab Question Answers

1. Levels become more closely spaced as  $n$  increases.
2. The transition produces light that has higher energy and shorter wavelength than what the eye can detect.
3. The  $n = 3 \rightarrow 2$  electronic transition is a smaller potential energy change in comparison to the  $n = 2 \rightarrow 1$  transition. When determining this, it is enough to compare the vertical distances in the level diagram.
4. Roy G Biv lists the colors of the visible spectrum in order of increasing energy (and decreasing wavelength).
5. "Absorbed" applies to light that decreases in intensity as it passes through a sample. "Transmitted" applies to light that passes through a sample.
6. An emission spectrum is the result of light produced by a sample that has been energized by an outside source. An absorption spectrum is the result of a sample selectively removing (absorbing) a section of the visible spectrum.
7. A device used to separate light into its spectral components (colors). More than a prism, a spectroscope supplies a scale that can be used to determine light wavelength.
8. Through the slit at the back of the spectroscope.
9. 525 nm (3 Sig Figs)
10.  $-2.180 \times 10^{-18}$  Joules.

## Stationary State Energy and Light Calculations

The potential energy of a electron in hydrogen stationary state depends on "n" and is given by

$$E_n = -2.180 \times 10^{-18} \cdot \left( \frac{1}{n^2} \right) \text{ Joules} \quad \text{Equation 1}$$

Notice that as n increases, the value of  $E_n$  increases as well.

When an electron transitions from  $n_i$  to  $n_f$ , it's change in potential energy is given by

$$\Delta PE = -2.180 \times 10^{-18} \cdot \left( \frac{1}{n_f^2} - \frac{1}{n_i^2} \right) \text{ Joules} \quad \text{Equation 2}$$

Notice the negative sign that is part of the calculation. This insures that the electron's potential energy change is negative for electron transitions that go from high to low stationary states.

The energy lost by the electron as it transitions is gained by the light that's released (Conservation of Energy). Therefore, the light's energy is equal to the  $\Delta PE_{\text{electron}}$  except that the sign is reversed:

$$\text{Energy}_{\text{light}} = 2.180 \times 10^{-18} \cdot \left( \frac{1}{n_f^2} - \frac{1}{n_i^2} \right) \text{ Joules} \quad \text{Equation 3}$$

Once calculated, the light energy can be converted into frequency ( $\nu$ ) via the equation:

$$E = h\nu \quad h = 6.6260755 \times 10^{-34} \text{ J} \cdot \text{s}$$

where  $\nu$  is frequency in Hertz (Hz) or  $\text{sec}^{-1}$ .

Finally, the light wavelength ( $\lambda$ ) is calculated *in meters* via the equation:

$$\lambda \times \nu = c \quad c = 3.00 \times 10^8 \text{ m/s}$$

Note that various units are used when reporting the wavelength of light. Here are several you should know:

nanometers:  $1 \text{ nm} = 1 \times 10^{-9} \text{ m}$  (exact)

Angstroms:  $1 \text{ \AA} = 1 \times 10^{-10} \text{ m} = 0.1 \text{ nm}$  (exact)

**Experiment:** Hazards identification

The mercury arc lamp used to calibrate the spectrometer in the next section emits dangerous ultraviolet light that is damaging to the eye. Never view this light source directly. A clear plastic shield should be used to screen out the ultraviolet rays while at the same time transmitting the visible light.

High voltage is present on the end-caps of the gas emission light sources. Do not touch these terminals (figure at right) while the light is in operation!

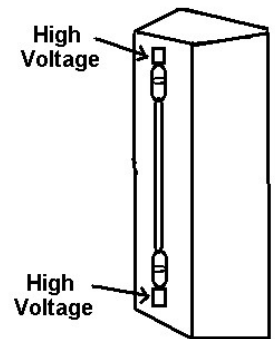

**Experiment:** Spectroscope Operation

Examine the spectroscope and locate the narrow slit (figure at right). Light enters the spectroscope through the thin slit so it's important to aim the slit accurately at the light source being studied.

While looking into the spectroscope (pointed end) you will observe a spectrum of light on left side projected on a scale. Hold the spectroscope horizontally while moving it left and right until the brightest spectrum is observed on the scale.

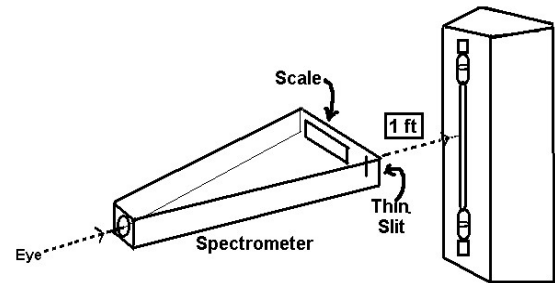

For best results, the spectroscope should be approximately 12 inches (30 cm) from the light source. A white light source is also used to illuminate the back of the spectroscope so that the scales can be seen.

When making a measurement, use only the lower "Wavelength (nm)" scale and record the measurement with 3 significant figures.

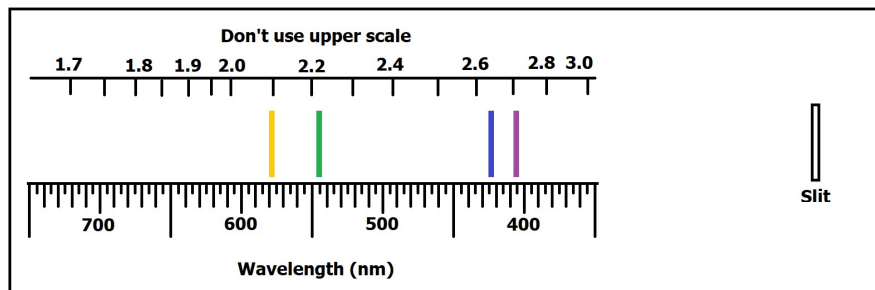

**Experiment:** Spectroscope Calibration

*The known wavelengths of lines in the mercury emission spectrum will be used to calibrate your spectroscope.*

Use your spectrometer to examine the mercury line spectrum. Record the positions of the mercury lines on the spectrometer's lower scale on the data sheet to the nearest +/- 1 unit (e.g. 432, 338. , etc).

Use Excel to construct a graph of

**Known mercury wavelengths (Y) vs. measured Hg wavelengths (X).**

Remember that Excel requires "X" data in a left column and "Y" data in a right column. Use only the "Scatter Plot" option.

Perform a trend line analysis of the data and display the straight-line equation and R squared value on the graph with 8 decimal place accuracy.

This graph and the trend line equation will be used to improve the accuracy of the hydrogen lines you measure.

## **Experiment: Atomic Emission Spectra**

*In the laboratory, you will find several of the following light sources available. It isn't necessary to examine them in this specific order. Use the small, white "night lights" as background lighting for the spectroscope scales.*

### **Experiment: High voltage discharge emission spectra:**

#### **Hydrogen**

Accurately sketch the spectrum in the space provided on your data sheet.

Record the measured wavelengths of the three hydrogen lines in your data sheet table (3 SF). A fourth line around 400 nm can sometimes be observed but is considered optional.

#### **Helium**

Accurately sketch the spectrum in the space provided on your data sheet.

#### **Neon**

Accurately sketch the spectrum in the space provided on your data sheet.

### **Experiment: Flame emission spectra:**

*(As this series of experiments must be performed in the hood, you will work in pairs to observe the spectra of various salts as they are incinerated in a Bunsen burner flame)*

Each salt solution is "misted" by the nebulizer apparatus. Record the identity of each salt solution, attach it to the nebulizer's compressed air line and direct the mist into the air vents of the Bunsen burner. For each salt solution, record the color of the flame.

Observe the emitted light through your spectroscope for each solution and record what you observe on your data sheet. You will be using these observations to identify an unknown mixture of aqueous salts so detailed observations are important! For each solution line positions when possible.

Disconnect the salt solution when finished and continue with the next salt solution: NaCl, CaCl<sub>2</sub>, BaCl<sub>2</sub>, SrCl<sub>2</sub>, LiCl, CuCl<sub>2</sub>

*Note: Chloride ions do not produce light in the visible spectrum. Observed spectra are due solely to the metal ions.*

Perform the same test on the unknown solution. You will compare the unknown spectrum to those measured above to determine what aqueous salts are present in the unknown.

### **Experiment: Molecular absorption spectra**

*Light that passes through a sample is transmitted.*

*In this series of experiments, you will examine the colors of light that successfully pass through several liquid samples.*

*A white light source is positioned on one side of the sample (figure at right). You and your spectroscope are positioned on the opposite side.*

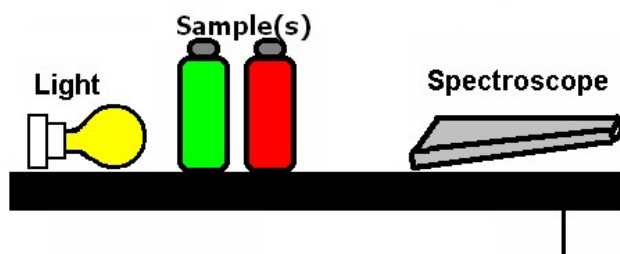

Observe the transmission spectrum of each food dye or dye combination with your spectroscope.

**Place an "X" in the square of the data table if the solution TRANSMITS that color of light.**

**Data Tables:** All entries must be in written in ink before you leave the lab.

**MERCURY Calibration Data Table:**

<b>Color</b>	<b>Measured Wavelength (nm)</b>	<b>Known Wavelength (nm)</b>
<b>Violet</b>		<b>404.7</b>
<b>Blue</b>		<b>425.8</b>
<b>Green</b>		<b>546.1</b>
<b>Yellow</b>		<b>579.0</b>

**Hydrogen Line Data:**

<b>Color</b>	<b>Measured Wavelength (nm)</b>	<b>Corrected Wavelength (nm)**</b>
<b>Violet<sub>1</sub>*</b>		
<b>Violet<sub>2</sub></b>		
<b>Blue-green</b>		
<b>Red</b>		

\* Very faint (optional)

\*\* Use Calibration Graph Trendline

***Spectroscope Calibration***

Record the measured wavelengths of the lines appearing in the mercury spectrum in the table above. These measurements should have three significant figures.

***Atomic Emission Spectra:***

***Hydrogen Emission Spectrum:***

Accurately sketch the hydrogen emission spectrum you observe in the space below.

For each line record its measured wavelength in the table above.

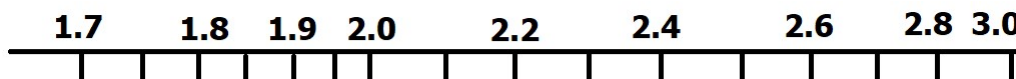

**Wavelength (nm)**

### **Helium Emission Spectrum:**

Accurately sketch the helium lines you observe in the space below.

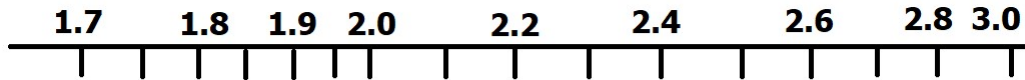

Wavelength (nm)

### **Neon Emission Spectrum**

Accurately sketch the neon lines you observe in the box below.

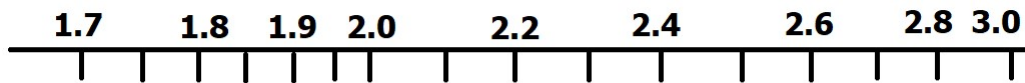

Wavelength (nm)

### **Flame Emission Spectra:**

Accurately sketch the emission spectrum in the space below. In some cases, instead of lines you will observe broader ranges of color. Do your best to shade in these areas paying close attention to where they begin and end. Record line positions as accurately as possible.

### **NaCl Flame Emission Spectrum**

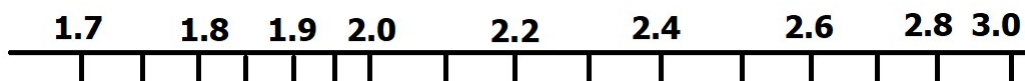

Wavelength (nm)



**CaCl<sub>2</sub> *Flame Emission Spectrum***

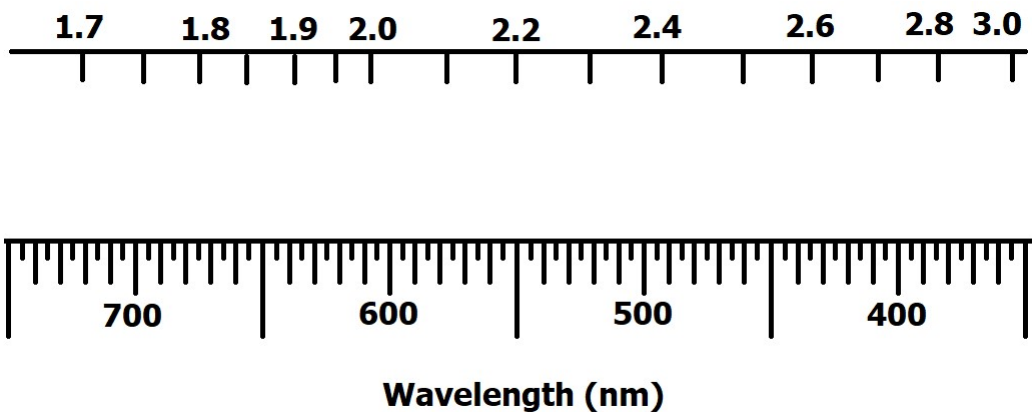

**NiCl<sub>2</sub> *Flame Emission Spectrum***

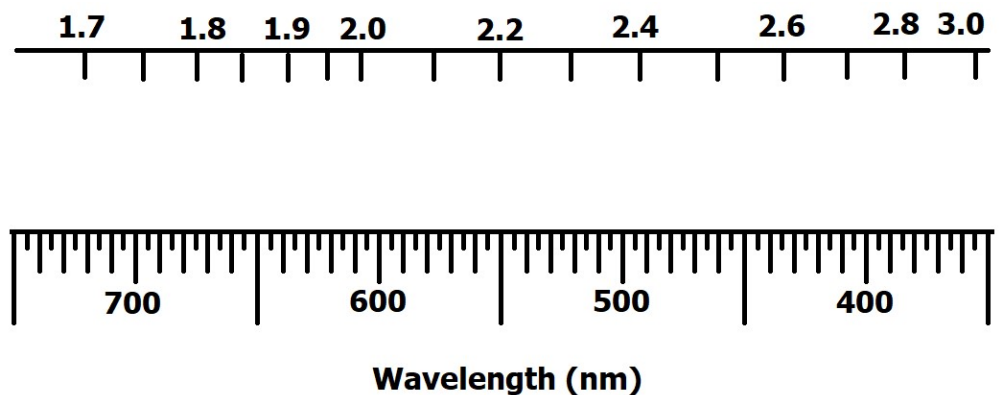

**SrCl<sub>2</sub> *Flame Emission Spectrum***

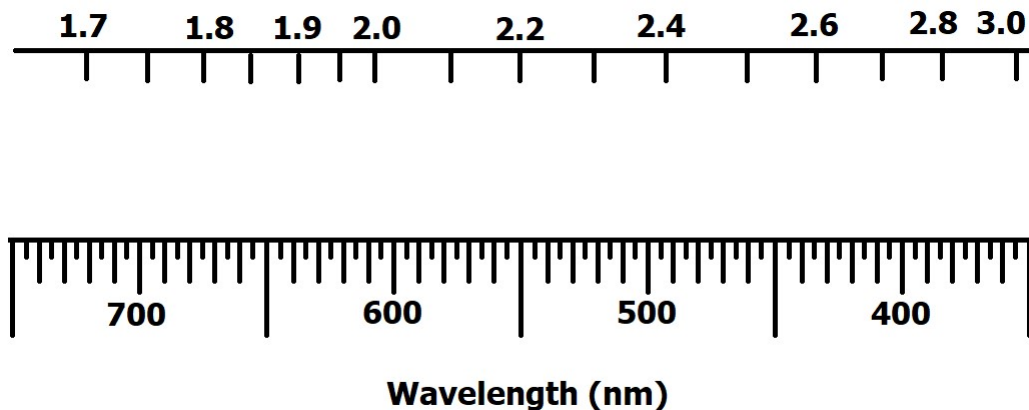

**LiCl** *Flame Emission Spectrum*

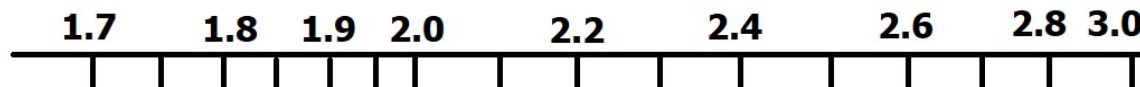

Wavelength (nm)

**CuCl<sub>2</sub>** *Flame Emission Spectrum*

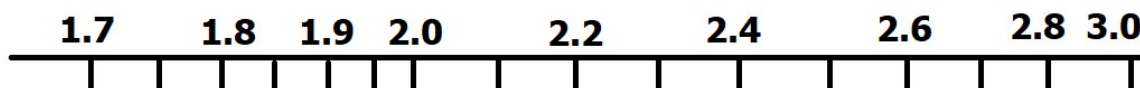

Wavelength (nm)

**Unknown** *Flame Emission Spectrum*

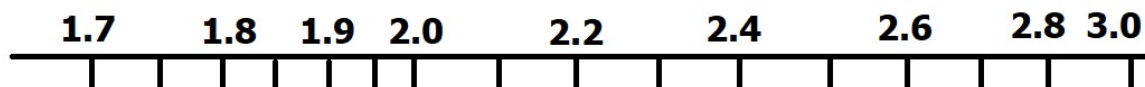

Wavelength (nm)

**Molecular absorption spectra:**

Place an "X" in the square of the data table if the solution TRANSMITS that color of light.

Dye Color	Red Light	Orange Light	Yellow Light	Green Light	Blue Light	Indigo Light	Violet Light
Red							
Blue							
Green							
Orange							
Red/Green							
Blue/Orange							
Red/Blue							

**Experimental Report**

The experimental report consists of ...

- All experimental data sheets and spectrum sketches (previous 4 pages)
- Calibration Graph
  - Graph the known Hg wavelengths (Y) vs the experimentally measured wavelengths.
  - Include proper titles, names, dates, axis labels, trendline equation and  $R^2$  value.
  - Print out the graph on a single sheet of paper and submit it with this report
- Answers to the following 4 questions.

**1. Molecular absorption:** Use the table above to determine the color(s) of light that would be transmitted if the red, green, orange and blue dye solutions were positioned one after the other.

---

**2. Flame Emission:** Compare the spectra of the known salt solutions with that of the unknown. What metal ions do you predict are in the unknown sample?

---

### 3. Atomic Emission:

a. Use the three measured hydrogen wavelengths and your trendline equation to determine the corrected wavelength in nanometer and meter units. Show your three calculations below and report your results in the data table with 3 sig. figs.

b. Use  $E = h\nu$ ,  $c = \lambda\nu$  and the corrected wavelengths (meters) of the three observed hydrogen lines to determine their corresponding energies  $E_{\text{violet}}$ ,  $E_{\text{green}}$ , and  $E_{\text{red}}$ . Show your three calculations below.

c. The three *visible* hydrogen lines, produced by  $n = 5 \rightarrow 2$ ,  $n = 4 \rightarrow 2$  and  $n = 3 \rightarrow 2$  electronic transitions, are known as the Balmer series. Use these  $n$  values and equation 3 to determine the energy of light emitted by each of the following transitions:  $E_{n=5 \rightarrow 2}$ ,  $E_{n=4 \rightarrow 2}$  and  $E_{n=3 \rightarrow 2}$ . Show your three calculations below.

- d. Calculate  $\Delta\%$  for each of the three energy light energy values using the calculation at right. Experimental energies come from part b and theoretical energies were determined in part c.

$$\Delta\% = \left( \frac{E_{\text{Experiment}} - E_{\text{Theoretical}}}{E_{\text{Theoretical}}} \right) \times 100\%$$

Be sure to include a + or – sign for each result since it tells us whether the experimental was high or low. Show your three calculations below.

4. The Lyman series is a progression of electronic transitions that end on hydrogen's  $n = 1$  energy level.

Use equation 2 to determine the energy of light that's emitted when an electron for the  $n = 2 \rightarrow 1$

Determine the wavelength of light this energy corresponds to in nanometers.

What type (microwave, etc.) of electromagnetic radiation is this and would you expect to see it?